

BMW i8 FRONT BRAKES

HYDRAULIC CIRCUIT

SYSTEM FILLING AND BLEEDING

- Remove cover in the luggage compartment (picture 7).
- Connect bleeder unit with max. 2 bar filling pressure. A second person is needed for this repair work.
- Check relevant equipment manufacturer's operating instructions for bleeder unit that will be used.
- Charging pressure should not exceed 2 bar.
- Connect bleeder unit (picture 8, n° 1) on expansion tank and switch on.
- Connect diagnostic equipment to vehicle and select brake bleeding procedure.
- Connect vent hose with collecting vessel (picture 9) to vent valve on rear right brake caliper. For all wheels the

- bleeding order is to start at the rear right, next rear left, front right and finally front left wheel.
- Open vent valve and purge until clear, bubble-free brake fluid emerges.
- Close vent valve; (torque front brake 10Nm, rear brake 15Nm).
- Switch off bleeder unit and remove from expansion tank.
- Check brake fluid level. If necessary, top up/draw off to "MAX" level.
- Close expansion tank.
- Pay attention to seal (picture 10, n° 1) in sealing cap.

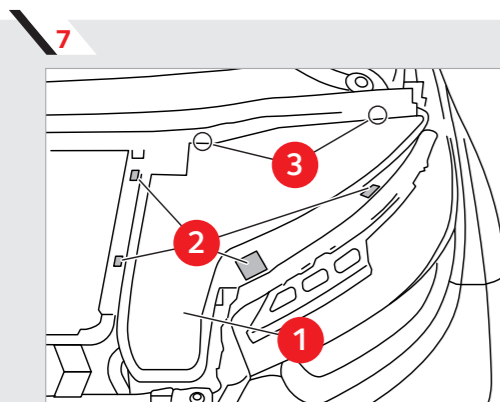

REMOVE COVER

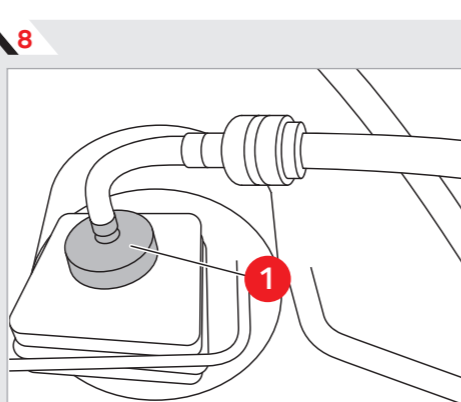

CONNECT BLEEDER UNIT

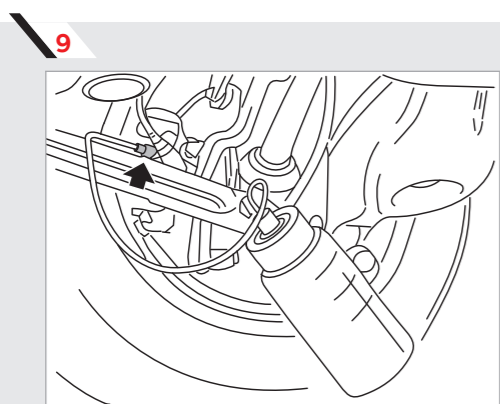

CONNECT VENT HOSE

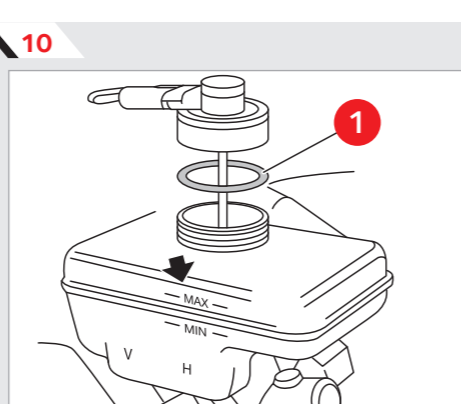

PAY ATTENTION TO SEAL IN SEALING CAP

HOW TO KEEP YOUR TECH STILL ON TREND



For more information on Garage Gurus, to further your automotive education, or to join the growing community, visit www.fmgaragegurus.eu or send an e-mail to garage-gurus@fmmotorparts.eu

www.ferodo.com

The content contained in this article is for informational purposes only and should not be used in lieu of seeking professional advice from a certified technician or mechanic. We are not liable for any damages resulting from your reliance on this content.

INSTALLATION GUIDE

BMW i8 FRONT BRAKES



BRAKE FLUID

BRAKE FLUID	
Product	DOT 4, Low viscosity
Capacity	1.0 litre
Maintenance intervals	Every 2 years

BRAKE FLUID DOT4 LOW VISCOSITY	
FBX025	250 ml
FBX050	500 ml
FBX100	1 lt



FERODO PART NUMBERS, BRAKE PAD SET

FDB4611 (set)	Brake pad	(mm)
OE: 34106866072	Length	114.6
34106872334	Height	91.3
WVA: 25028	Thickness	18
Brake system: Brembo		



SAFETY INFORMATION FOR HANDLING ELECTRIC/HYBRID VEHICLES:

WARNING



HIGH-VOLTAGE SYSTEM - DANGER TO LIFE

Each job on the vehicle must be assigned by properly trained personnel. Before work is started, this person must place the vehicle in the operating condition required to perform the relevant activity. The instructions and directions given by this person must be followed. No work may be carried out without this qualified person being consulted first.

www.ferodo.com

BMW i8 FRONT BRAKES

BRAKE PADS

REMOVAL

- Position vehicle onto a lift.
- Remove the front wheels.
- Remove brake pad wear sensor, pull it out forward of the brake pad (left side only).
- Drive out retaining pins (Picture 1, n°2).
- Remove expanding spring (Picture 1, n°3).
- Remove brake pads (Picture 1, n°4).

ASSEMBLY

- Check minimum brake thickness (written on disc, 18,4 mm minimum)
- Slightly bevel edges in the area shown in picture 2, n°1. (Dimension A must not exceed maximum 1 mm)

- Press brake piston fully back with the right caliper tool. (Note brake fluid level in expansion tank)
- Check dust boot for damage and renew if necessary.
- Clean the following surfaces and apply a thin coating of brake paste on:
 - contact surface (picture 3, n°1) of brake piston.
 - both sides of the contact surface of the pads in area 1 and 2 (picture 4).
 - the brake pad contact surface on both sides as shown in picture 5, n°1.

- Install new brake pads.
- Align brake pads with the retaining pins in the brake caliper.
- Fully depress brake pedal several times so that brake pads contact brake discs.
- Fit retaining pins and expanding spring.

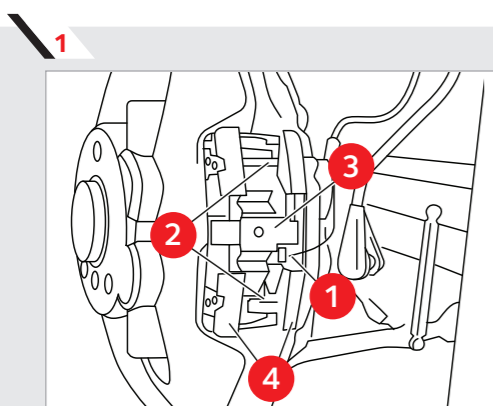

REMOVE BRAKE PADS

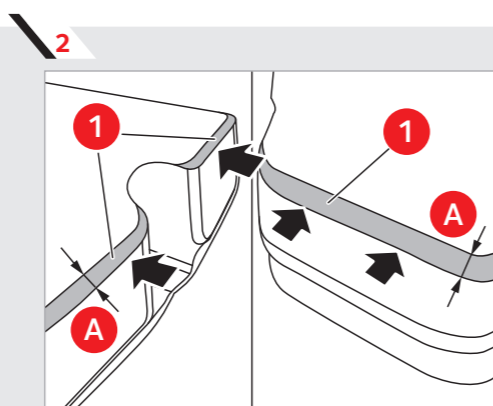

SLIGHTLY BEVEL EDGES OF THE PAD

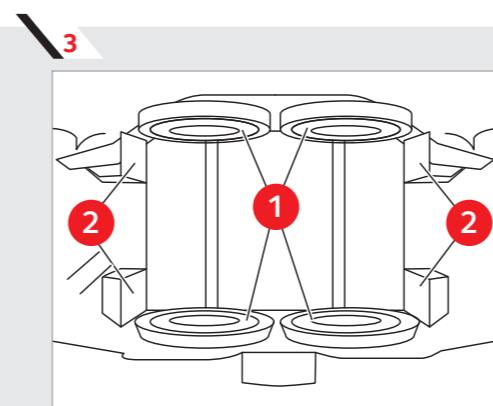

CLEAN THE CONTACT SURFACE AND APPLY BRAKE PAD PASTE

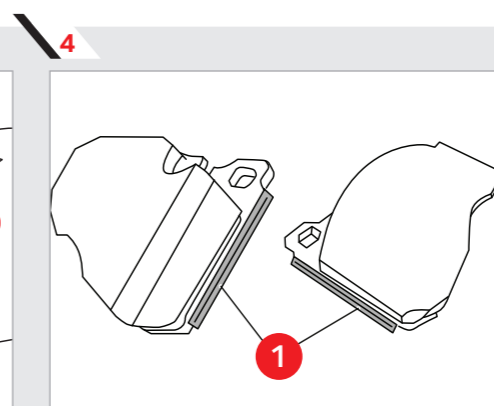

CLEAN THE CONTACT SURFACE AND APPLY BRAKE PAD PASTE

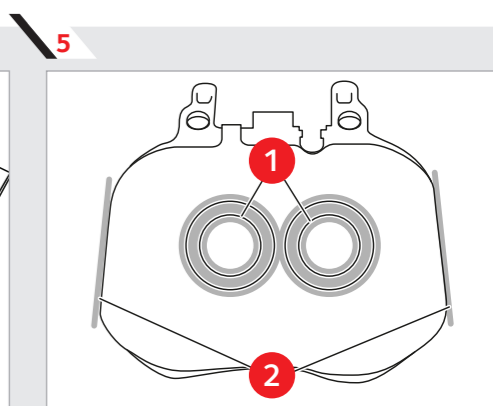

CLEAN THE CONTACT SURFACE AND APPLY BRAKE PAD PASTE

BRAKE DISCS

REMOVAL

- Remove front wheels
- Release screws (picture 6, n°1) and remove brake calliper towards rear and tie it up.
- Remove and clean brake pads.
- Check the thickness of the brake disc, this should be at least 18.4 mm
- Release both screws and remove brake disc.

ASSEMBLY

- Clean contact surface of brake disc at wheel hub and remove corrosion. Unevenness on contact surface may result in distortion of brake disc.
- Replace screws from anchor plate (30NM plus 90 °).
- Replace screws that holds the disc (tightening torque 16 Nm).

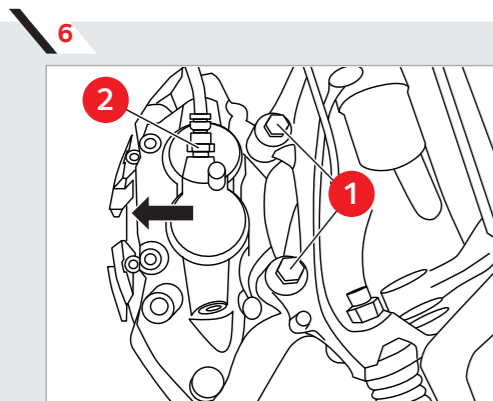

REMOVE BRAKE CALLIPER

WARNING



- To release brake disc: Do not strike friction ring with a hammer or similar! If necessary, carefully tap on the base of brake disc chamber with a rubber mallet.
- After completing work: Carry out test braking while driving at low speed.
- Advise the customer to try to avoid drastic braking during the first 200 km after brake replacement.
- If the brake discs are replaced, you must also fit new brake pads.
- Brake discs may only be replaced in pairs (on each axle).

WARNING



- Retaining pins and expanding spring: for vehicles older than 48 months it is recommended to replace the retaining spring!
- Brake pad wear sensor: After removal it must be replaced (brake pad wear sensor loses its retention capability in the break pad).
- Tie brake caliper and do not allow it to hang from brake hose.
- When pressing piston back, note brake fluid level in expansion tank. Overflowing brake fluid will damage the paintwork.
- When installing new brake pads, the brake fluid level must be brought up to max. mark.
- Carry out test braking while driving at low speed.
- Advise the customer to try to avoid drastic braking during the first 200 km after brake replacement.